

ACVATIX™

On/Off PICV, PN 25

VQP46.., VQP46..Q, VQI46.., VQI46..Q



VQP46..

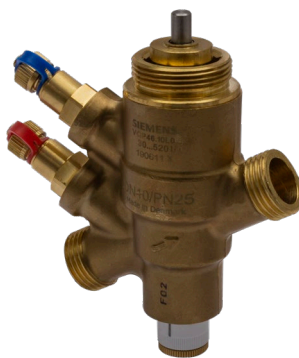

VQP46..Q

with pressure test points P/T



VQI46..

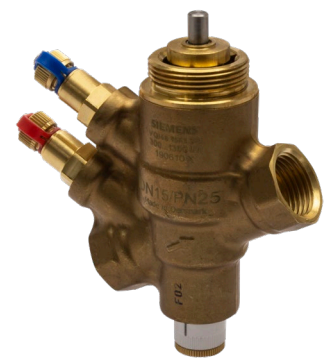

VQI46..Q

with pressure test points P/T

For rooms, zones, ventilation and air-conditioning systems

- Integrated differential pressure controller
- Valve body made of dezincification resistant hot-pressed brass (DZR)
- Volumetric flow 30...1800 l/h
- Differential pressure range 17...600 kPa
- Internally threaded Rp conforming to ISO 7-1
- Externally threaded G conforming to ISO 228-1
- Version with pressure test points for Δp measurement (optional)
- Can be equipped with electrothermal or electromotive actuators
 - STA..
 - SUE21P (2-position)

Use

- In ventilation and air conditioning plants for control on the water side and automatic hydraulic balancing of terminal units, such as fan coils, induction units, and in heat exchangers for heating and cooling, with 2-point control
- In heating zones, such as self-contained heating systems, apartments, individual rooms, etc.
- For closed circuits

Technical design

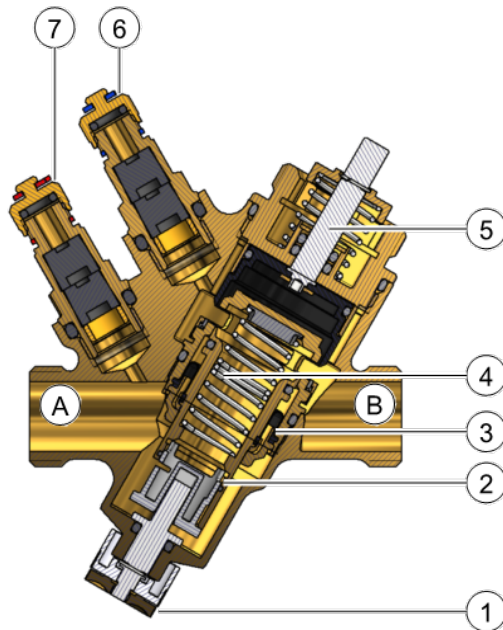

- 1 Ring with dial for presetting
 - 2 Variable presetting opening
 - 3 Differential pressure controller
 - 4 Flow control valve
 - 5 On/Off control valve
 - 6 Pressure test point, blue ribbon, P-
 - 7 Pressure test point, red ribbon, P+
- A Inlet port
B Outlet port B

PICV VQ..46..Q (shown here) is additionally equipped with pressure test points P/T.

Functional principle

The above drawing is used as a reference for this following description.

The medium entering the valve (inlet port A) passes through the variable presetting opening [2] which is connected to the ring with the dial [1] for presetting the desired maximum volumetric flow. Then, the medium flows through the On/Off control valve [5].

The actuator opens and closes the On/Off control valve [5]. After the presetting, the medium passes through a built-in mechanical differential pressure controller [3]. This differential pressure controller is the heart of the PICV and ensures that the selected volumetric flow is maintained across the whole working range and independent of the inlet pressure P_1 .

The PICV VQ..46..Q are additionally equipped with 2 pressure test points (P+, P-). These pressure test points allow the measurement of the differential pressure across the PICV in order to check if the Δp is sufficient to reach Δp_{\min} . For that purpose, the electronic manometer ALE10 can be used.

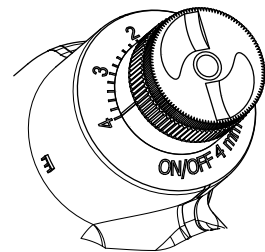

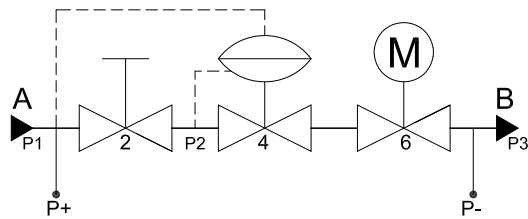

- A Inlet medium (inlet port)
- B Outlet medium (outlet port)
- 2 Ring with dial for presetting
- 4 Differential pressure controller maintains the pressure P1 – P2 constant across the presetting [5]
- 6 On/Off control valve with mounted actuator

- P1 Pressure at inlet of PICV
- P2 Pressure at outlet of presetting
- P3 Pressure at outlet of PICV
- P+ P/T port, pressure test point with red ribbon [7]
- P- P/T port, pressure test point with blue ribbon [6]

Manual control

The manual control knob can be fitted to protect the valve stem and facilitates manual control of the PICV during commissioning. The manual control knob is delivered loose in the box.

Factory setting:

The valve is open. To close the valve, turn the manual knob clockwise. The valve must be open to purge the system.

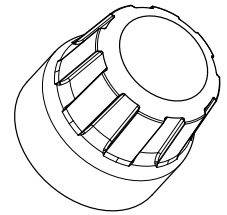

Sizing

Engineering example

Basis of calculation

1. Determine energy demand Q [kW]
 2. Determine temperature differential (supply – return) ΔT [K]
 3. Calculate volumetric flow

$$\dot{V} = \frac{Q[\text{kW}] \cdot 1000}{1,163 \cdot \Delta T[\text{K}]} \left[\frac{\text{l}}{\text{h}} \right]$$
 Hint: you can also determine the volumetric flow using the valve slide rule.
 4. Select suitable PICV
 - Pipe connections (internally or externally threaded)
 - With or without P/T ports
 - Ideally, PICVs should be selected such that they operate at about 80 % of their maximum flow, enabling them to deliver spare capacity, if required.
- ⇒ Determine dial setting using volumetric flow/dial presetting table, cf. Volumetric flow/dial presetting [→ 4]

Example

- ▷ Given is a heat exchanger with:
1. Energy demand: Q = 1.9 kW
 2. Temperature differential: $\Delta T = 6$ K
 3. Volumetric flow:

$$\dot{V} = \frac{1.9 \text{ kW} \cdot 1000}{1,163 \cdot 6 \text{ K}} = 272.28 \text{ l/h}$$

4. The valve shall have connections with external threads to ISO 228-1 and size DN 15.
 - PICV selection:
VQP46.15L0.5 (externally threaded connections, no pressure test points P/T, nominal volumetric flow 520 l/h)
5. Volumetric flow: 270 l/h
Dial setting: 2.6

Volumetric flow/dial presetting

Tables to determine the dial setting for a desired volumetric flow.

Δp_{\min} [kPa] based on volumetric flow; interpolate missing values.

	NOTICE
	Presetting tables indicate expected nominal volumetric flow
	During commissioning, check whether current pre-settings correspond to planned design.
	<ul style="list-style-type: none"> • Further adjustment of pre-settings may be required to achieve needed volumetric flow.

	Presetting range non-linear ¹⁾
	Presetting range non-linear
	Presetting range not permitted

VQP46.10L0.5, VQP46.10L0.5Q																				520 l/h nominal		
\dot{V} [l/h]				30	45	60	76	95	116	140	167	197	231	267	305	345	385	424	460	493	520	
Dial	Min.	0.2	0.4	0.6	0.8	1	1.2	1.4	1.6	1.8	2	2.2	2.4	2.6	2.8	3	3.2	3.4	3.6	3.8	Max.	
Δp_{\min} [kPa]				17	22	26	26	27	28	29	30	30	30	30	30	30	30	30	30	30	30	30

VQP46.15L0.5, VQP46.15L0.5Q, VQI46.15L0.5, VQI46.15L0.5Q																				520 l/h nominal		
\dot{V} [l/h]				30	45	60	76	95	116	140	167	197	231	267	305	345	385	424	460	493	520	
Dial	Min.	0.2	0.4	0.6	0.8	1	1.2	1.4	1.6	1.8	2	2.2	2.4	2.6	2.8	3	3.2	3.4	3.6	3.8	Max.	
Δp_{\min} [kPa]				19	23	27	27	27	27	28	28	28	28	28	28	28	28	28	28	28	28	28

VQP46.15F1.3, VQP46.15F1.3Q, VQI46.15F1.3, VQI46.15F1.3Q																				1300 l/h nominal		
\dot{V} [l/h]				300	411	500	573	636	692	746	800	855	913	974	1037	1100	1161	1216	1261	1291	1300	
Dial	Min.	0.2	0.4	0.6	0.8	1	1.2	1.4	1.6	1.8	2	2.2	2.4	2.6	2.8	3	3.2	3.4	3.6	3.8	Max.	
Δp_{\min} [kPa]				27	27	27	27	27	27	27	27	27	27	27	27	27	27	27	28	28	28	28

VQP46.20F1.5, VQP46.20F1.5Q, VQI46.20F1.5, VQI46.20F1.5Q																				1500 l/h nominal		
\dot{V} [l/h]				320	411	500	586	669	749	826	900	971	1040	1106	1169	1230	1288	1344	1398	1450	1500	
Dial	Min.	0.2	0.4	0.6	0.8	1	1.2	1.4	1.6	1.8	2	2.2	2.4	2.6	2.8	3	3.2	3.4	3.6	3.8	Max.	
Δp_{\min} [kPa]				35	35	35	35	35	35	35	35	35	35	35	35	35	35	35	35	35	35	35

VQP46.25F1.8, VQP46.25F1.8Q, VQI46.25F1.8, VQI46.25F1.8Q																				1800 l/h nominal		
\dot{V} [l/h]				620	731	850	971	1089	1198	1296	1380	1450	1505	1546	1577	1600	1640	1680	1720	1760	1800	
Dial	Min.	0.2	0.4	0.6	0.8	1	1.2	1.4	1.6	1.8	2	2.2	2.4	2.6	2.8	3	3.2	3.4	3.6	3.8	Max.	
Δp_{\min} [kPa]				30	30	30	30	30	30	30	30	30	30	30	30	30	30	30	31	31	31	31

¹⁾ Using a linear interpolation will cause a minor offset.

Valve characteristic

Since the VQP/VQI is an On/Off PICV, the valve characteristic is not based on a modulating function. The valve characteristic is made up of two operating points:

- The PICV is closed at stroke $H/H_{100} = 0$ and volumetric flow $V/V_{100} = 0$
- The PICV is open at stroke $H/H_{100} = 1$ and volumetric flow $V/V_{100} = 1$

Type summary

Type	Stock no.	DN	H ₁₀₀ [mm]	Connections		Test points P/T-ports	V̇ _{min} [l/h]	V̇ ₁₀₀ [l/h]
				[inch]				
VQP46.10L0.5	S55264-V134	10	4	G ½	Externally threaded	No	30	520
VQP46.10L0.5Q	S55264-V133					Yes		
VQP46.15L0.5	S55264-V138	15		G ¾		No	300	1300
VQP46.15L0.5Q	S55264-V137					Yes		
VQP46.15F1.3	S55264-V142	20		G 1		No	320	1500
VQP46.15F1.3Q	S55264-V141					Yes		
VQP46.20F1.5	S55264-V146	25		G 1 ¼		No	620	1800
VQP46.20F1.5Q	S55264-V145					Yes		
VQP46.25F1.8	S55264-V150	25	G 1 ¼	No	620	1800		
VQP46.25F1.8Q	S55264-V149			Yes				

Type	Stock no.	DN	H ₁₀₀ [mm]	Connections		Test points P/T-ports	V̇ _{min} [l/h]	V̇ ₁₀₀ [l/h]
				[inch]				
VQI46.15L0.5	S55264-V136	15	4	Rp ½	Internally threaded	No	30	520
VQI46.15L0.5Q	S55264-V135					Yes		
VQI46.15F1.3	S55264-V140	20		Rp ¾		No	300	1300
VQI46.15F1.3Q	S55264-V139					Yes		
VQI46.20F1.5	S55264-V144	25		Rp 1		No	320	1500
VQI46.20F1.5Q	S55264-V143					Yes		
VQI46.25F1.8	S55264-V148	25		Rp 1		No	620	1800
VQI46.25F1.8Q	S55264-V147					Yes		

DN = Nominal size

H₁₀₀ = Nominal stroke

V̇_{min} = Smallest pre-settable volumetric flow through fully open valve (H₁₀₀)

V̇₁₀₀ = Volumetric flow through fully open valve (H₁₀₀)

Delivery

PICVs, actuators and accessories are packaged and supplied separately.

Accessories

Type	Stock no.		Description
ALE10	ALE10		<p>Electronic manometer excluding measuring lines and measuring tips. Measuring range 0...700 kPa. A differential pressure of more than 1000 kPa will destroy the pressure sensor.</p> <p>For measuring the differential pressure between P+ and P- of the PICVs (refer to drawing under Functional principle [-> 2]).</p> <p>Functions of the manometer:</p> <ul style="list-style-type: none"> • Start/stop • Automatic zero position • Backlit display • Display: Out → outside the measuring range • Holding function
ALE11	ALE11		<p>Measuring lines and straight measuring tips for use with Siemens PICVs.</p> <p>Equipped with G 1/8 " connection with 2 x 40 mm needles.</p>
ALP45	ALP45		<p>Spare nipples P/T port (set of 2).</p> <p>Set contains 1 piece each with a red and blue ribbon.</p> <p>Port: External threads G 1/8 " to ISO 228</p> <p>Connection to valve body: G 1/4 " to ISO 228, including O-ring</p> <p>Length: 40 mm</p>
ALP46	S55264-V115		<p>Blanking plug for P/T ports.</p> <p>Connection to valve body: G 1/4 " to ISO 228, including O-ring</p>
ALP47	S55264-V116		<p>Drain ball valve including O-ring.</p> <p>Port: External threads G 1/2 " to ISO 228</p> <p>Connection to valve body: G 1/4 " to ISO 228, including O-ring</p> <p>Length: 48 mm</p>
ALP48	S55264-V117		<p>Combined P/T port and drain ball valve with red ribbon.</p> <p>Port: External threads G 1/8 " to ISO 228</p> <p>Connection to valve body: G 1/4 " to ISO 228, including O-ring</p> <p>Length: 80 mm</p>
ALP49	S55264-V118		<p>Long P/T ports (set of 2).</p> <p>Set contains 1 piece each with a red and blue ribbon.</p> <p>Port: External threads G 1/8 " to ISO 228</p> <p>Connection to valve body: G 1/4 " to ISO 228, including O-ring</p> <p>Length: 120 mm</p>
ALP53	S55264-V153		<p>Spare valve protection cap, black</p>
ALP54	S55264-V154		<p>Special tool for loosening and removing the On/Off PICV bonnet in order to remove the differential pressure regulator for replacement or cleaning</p>

Fittings

Type	Stock no.	Description
ALG132	ALG132	Set of 2 fittings with threaded connections for 2-port valves, consisting of 2 union nuts, 2 discs and 2 flat seals.
ALG142	ALG142	

Ordering (example)

Type	Stock no.	Description
VQP46.15L0.5	S55264-V138	On/Off PICV, PN 25, externally threaded
STA23	S55174-A101	Actuator

Equipment combinations

Actuators

Type	Operating voltage	Positioning		Actuators (no power) ¹⁾	Spring return	Stroke	Connecting cable	Data sheet
		signal	force					
SUE21P	AC 230 V	2-Punkt	100 N	NC	Nein	Max. 4.5 mm	0.8 m	A6V11780777
STA121..	AC / DC 24 V							
STA321..	AC 230V							
STP121..	AC / DC 24 V							
STP321..	AC 230V	DC 0...10 V	110 N	NO	Nein	Max. 4.5 mm	1 m / 2 m / 5 m	A6V12986007
STP161.L10	AC 24 V							
STP561.L10	DC 24 V							
STA161.L10	AC 24 V							
STA561.L10	DC 24 V			NC			1 m	

- ¹⁾ NC = Normally closed = VQP46..VQI46.. powerless closed
 NO = Normally open = VQP46..VQI46.. powerless open
 The valve is fully opened without an actuator

Fittings

PICV		Set of fittings	
Externally threaded		Brass	
Type	Stock no.	Type	Stock no.
VQP46.10L0.5	S55264-V134	ALG132 ¹⁾	ALG132
VQP46.10L0.5Q	S55264-V133		
VQP46.15L0.5	S55264-V138	ALG142 ¹⁾	ALG142
VQP46.15L0.5Q	S55264-V137		
VQP46.15F1.3	S55264-V142		
VQP46.15F1.3Q	S55264-V141		
VQP46.25F1.8Q	S55264-V149		

- ¹⁾ Connecting thread pipe side: Internally threaded

Title	Content	Document ID:
Mounting instructions VQP46., VQP46..Q, VQI46., VQI46..Q	Mounting instructions	A6V11878322
Electrothermal actuators STA..3., STP..3..	Data sheet: product description	CE1N4884en
Mounting instructions Actuators STA..3., STP..3..	Mounting instructions	M4884
Electromotoric actuator SUE21P	Data sheet: product description	A6V11780777
Mounting instructions Actuators SUA21/3P, SUE21P	Mounting instructions	A6V11678006
Mounting instructions actuators STA.. STP..	Mounting instructions	AV12984110
Electrothermal actuators STA.. STP..	Data sheet: product description	AV12986007

Related documents such as environmental declarations, CE declarations, etc., can be downloaded at the following Internet address:

<http://siemens.com/bt/download>

Notes

Security

	<p>⚠ CAUTION</p>
	<p>National safety regulations</p> <p>Failure to comply with national safety regulations may result in personal injury and property damage.</p> <ul style="list-style-type: none"> Observe national provisions and comply with the appropriate safety regulations.

Engineering

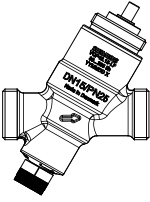
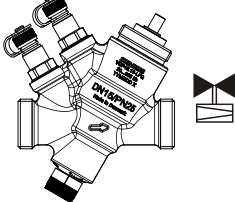
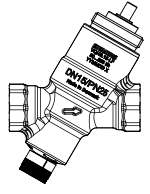
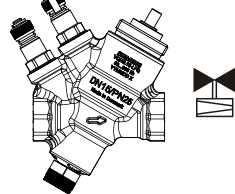
Valve	Symbols / Direction of flow		Flow in control mode	Valve stem	
	VQ..46..	VQ..46..Q		retracts	extends
On/Off PICV VQP46..			constant	closes	opens
On/Off PICV VQI46..					

	<p>⚠ CAUTION</p>
	<p>The direction of flow indicated by the arrow on the valve body is mandatory!</p>

The valves should preferably be mounted in the return pipe where temperatures are lower and where the sealing gland is less affected by strain.

Symbols

Symbol used in catalogs and application descriptions	Symbol used in diagrams
	There are no standard symbols for PICVs in diagrams.

Recommendation

A strainer or dirt trap should be fitted upstream of the valve to enhance reliability. Remove dirt welding beads, etc. from valves and pipes.

Do not insulate the actuator bracket, as air circulation must be ensured!

Installation

Presetting

Presetting can be done with or without the actuator mounted.

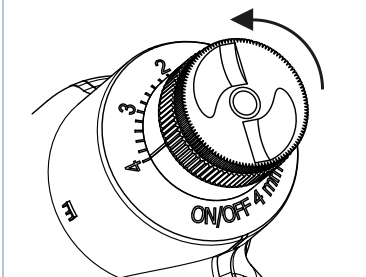
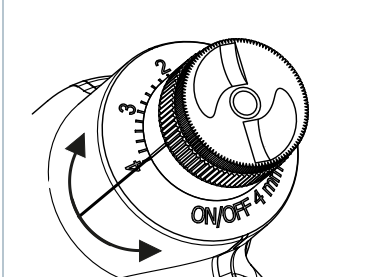
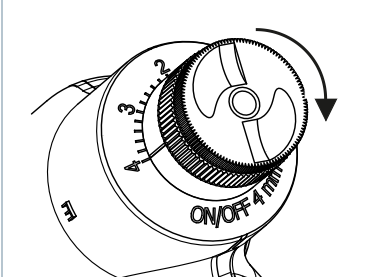
1. Loosen knurled nut.	2. Adjust the desired dial setting with the white knob.	3. Retighten knurled nut by hand.
		

Mounting

PICV and actuator can be straightforwardly assembled on site. Special tools or adjustments are not required.

Prior to mounting the actuator, the required volumetric flow must be set.

The valve is supplied complete with Mounting Instructions (A6V11878322).

Mounting positions

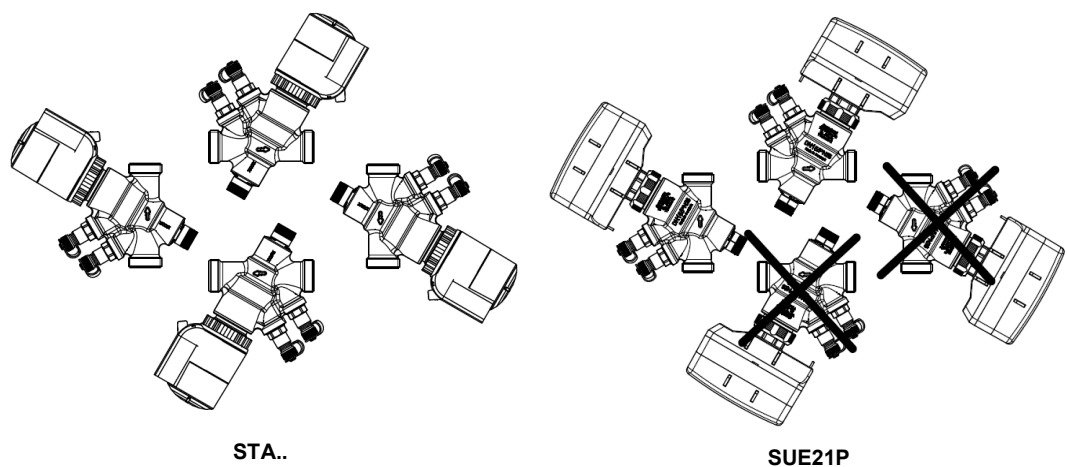

Thermal actuators STA.. may be installed in any position.

Actuator SUE21P must be installed horizontally up to 90° and not hanging.

Commissioning

	⚠ CAUTION
	Strong pressure impacts can damage closed PICVs. <ul style="list-style-type: none">• The PICVs must be commissioned with the manual control knob or actuator correctly fitted.• The PICVs must be open when flushing or pressure testing the system. Flush only on correct flow direction.• Differential pressure Δp_{\max} across the valves's control path is not allowed to exceed 600 kPa

Manual control

When turning the manual control knob in counterclockwise direction or manually operating the actuator, the valve opens. The actuator closes the valve. The valves are supplied fully open. The manual knob is not designed for permanent manual operation.

Maintenance

The VQP/VQI46.. PICVs are maintenance-free without differential pressure regulator. Valve plug stem, presetting, diaphragm etc. may not be disassembled.

	⚠ CAUTION
	When performing service work on the valve and/or actuator: <ul style="list-style-type: none">• Switch off the pump and disconnect power supply.• Close the shut-off valves in the piping network.• Fully reduce pressure in the piping network and allow the pipes to cool down completely.

Differential pressure regulator cleaning

General notes

The valve insert with the differential pressure regulator can be removed for replacement or cleaning. The removal of the valve from the pipeline is not necessary for this operation. For the cleaning process of the differential pressure regulator, a special tool is needed (ALP54, see Accessories [→ 6]).

Disassemble

1. Loosen the knurled nut

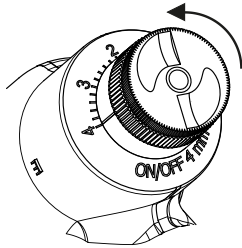

2. Place the special tool on the On/Off bonnet

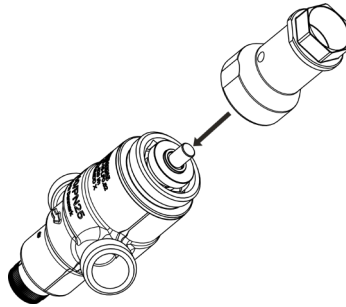

3. Loosen the On/Off bonnet

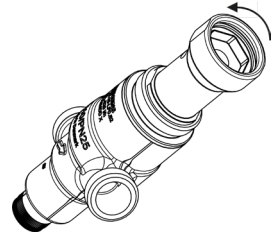

4. Remove the On/Off bonnet from the valve housing

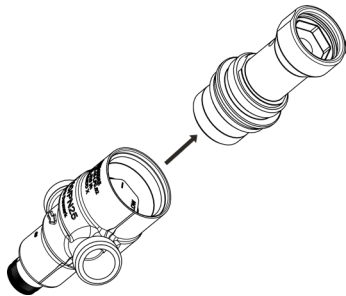

5. Place the 19 mm top on the differential pressure regulator

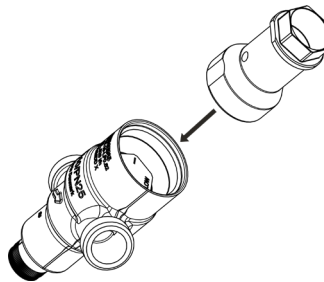

6. Loosen the differential pressure regulator

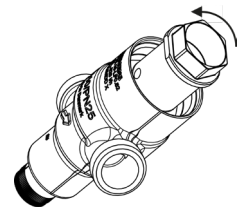

7. Remove the differential pressure regulator from the valve housing

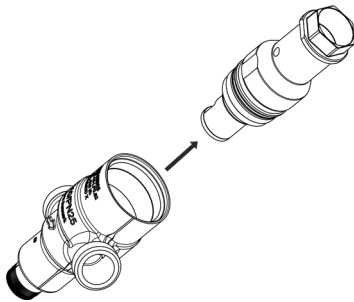

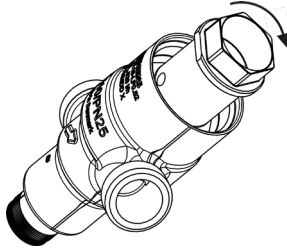
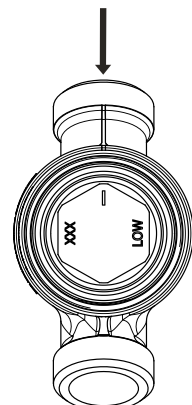
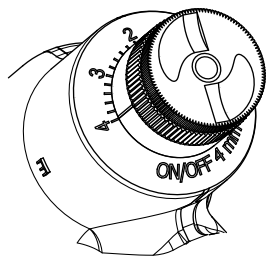
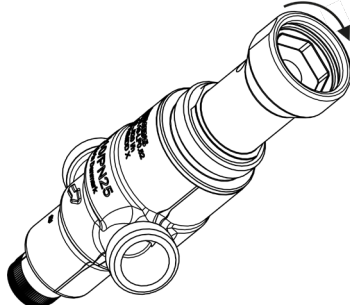
Assemble		
<p>1. Insert the differential pressure regulator and tighten the regulator to stop</p> 	<p>2. Loosen the differential pressure regulator until the marking on the regulator is aligned against the flow direction</p> 	<p>3. Orient the indicator in fully open position to presetting Re-adjust Step 2 if necessary</p> 
<p>4. Insert the On/Off bonnet and tighten with 20 Nm</p> 		

Sealing gland

The stem sealing gland cannot be exchanged. Should leakage occur, the whole valve must be replaced.

Disposal

	<p>▲ WARNING</p>
	<p>Tensioned return spring Opening the valve housing can release the highly tensioned return spring, which can cause flying parts and injuries.</p> <ul style="list-style-type: none"> • Do not open the valve housing.

The valve should not be disposed of as domestic garbage.

- Special treatment for individual components may be required by law or make ecological sense.
- Comply with all local and currently applicable laws and regulations.

Warranty

Technical data on specific applications are valid only together with Siemens products listed under "Equipment combinations". Siemens rejects any and all warranties in the event that third-party products are used.

Technical data

Functional data		
PN class		PN 25 as per EN 1333
Permissible operating pressure		2500 kPa (25 bar) as per ISO 7628 / EN 1333
Differential pressure	Max.	600 kPa
	Min.	See tables in Volumetric flow/dial presetting [→ 4]
Valve characteristic		On/Off
Operating direction		Normally open (push to close)
Leakage rate in general		Class IV (0...0.01 % of volumetric flow V_{100}) to EN 1349
Average flow accuracy		$\pm 5\%$ up to $\pm 10\%$ from Δp_{\min} ...600kPa
Permissible media		Low-temperature water
		Chilled water
		Water with antifreeze
	Recommendation	Water treatment to VDI 2035
Medium temperature	Valve with actuator	1...90 °C
Nominal stroke		4.0 mm

General ambient conditions		
Operation		IEC 60721-3-3
	Environmental conditions	Class 3K5
	Temperature	0...55 °C
	Humidity	5...95 % r.h.
Transport		IEC 60721-3-2
	Environmental conditions	Class 2K3
	Temperature	-30...65 °C
	Humidity	< 95 % r.h.
Storage		IEC 60721-3-1
	Environmental conditions	Class 1K3
	Temperature	-15...50 °C
	Humidity	5...95 % r.h.

Materials			
Valve	Body	Port	Dezincification resistant hot-pressed brass (DZR), CW602N
	Seat	Sealing gland	
	Test points		
Stem	Spring		Stainless steel
Presetting element			PPO and ABS
On/off piston			PPS
Seals	Diaphragm		EPDM, HNBR
Seat	Damper		

Dimensions / weight		
Dimensions		Cf. Dimensions [→ 16]
Threaded connections	VQP46..	G to ISO 228-1 (externally threaded)
	VQI46..	Rp to ISO 7-1 (internally threaded)
Actuator connection	DN 10...25	M30 x 1.5 mm
Pressure test points (P/T-ports)	Connection valve body	G ¼ "
	Needles	2 mm x 40 mm
Weight		Cf. Dimensions [→ 16]

Standards, directives and approvals		
Pressure Equipment Directive		PED 2014/68/EU
Pressure-carrying accessories	Scope	Article 1, section 1
	Definitions	Article 2, section 5
Fluid group 2	DN 10...25	Without CE-marking as per article 4, section 3 (sound engineering practice) ¹⁾
EAC conformity		Eurasia conformity

Environmental compatibility

The product environmental declarations A5W00077471 (VQP46..) and A5W00077470 (VQI46..) ²⁾ contain data on environmentally compatible product design and assessments (RoHS compliance, material composition, packaging, environmental benefit, and disposal).

¹⁾ Valves where PS x DN < 1000 do not require special testing and cannot carry the CE label.

²⁾ The documents can be downloaded at <http://siemens.com/bt/download>.

Application examples

PICVs in HVAC systems combined with variable speed pumps provide even higher energy efficiency. When sizing the pump, it must be made certain that the most critical branch or consumer in the system – usually the most remote from the pump – receives enough pressure (pump head). Thus, it is recommended to use a variable speed pump in constant-pressure mode with end-point feedback, to maintain a minimum differential pressure across the critical valve.

Residential buildings

Residential buildings with, for example, self-contained flat heating systems:

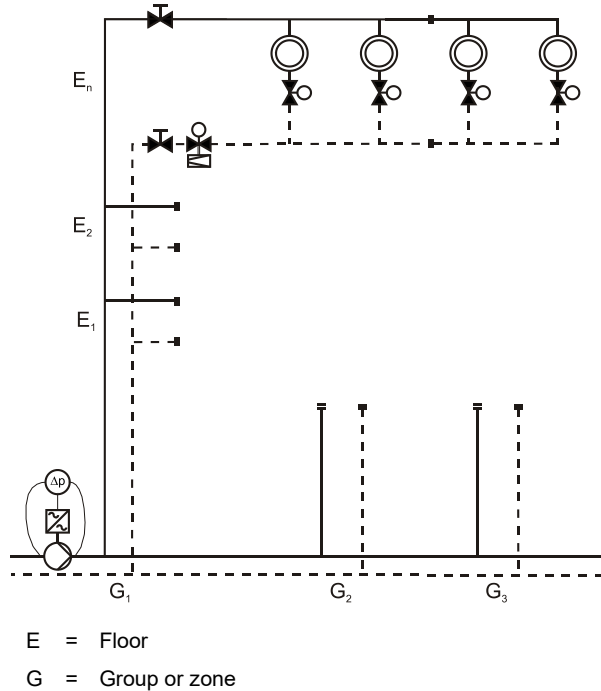

Non-Residential buildings

Commercial buildings with, for example, fan coil units or heat exchangers for heating or cooling:

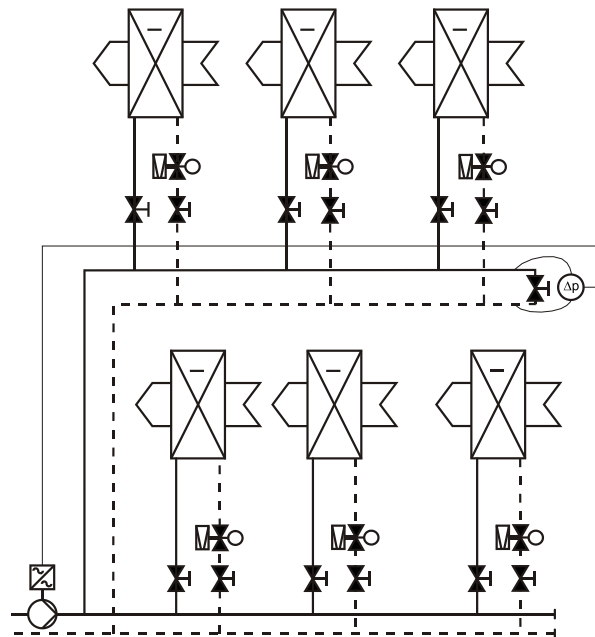

Dimensions

VQP46..

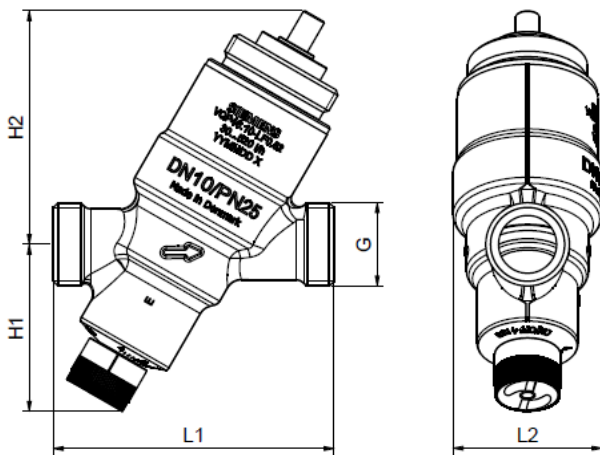

VQP46..Q

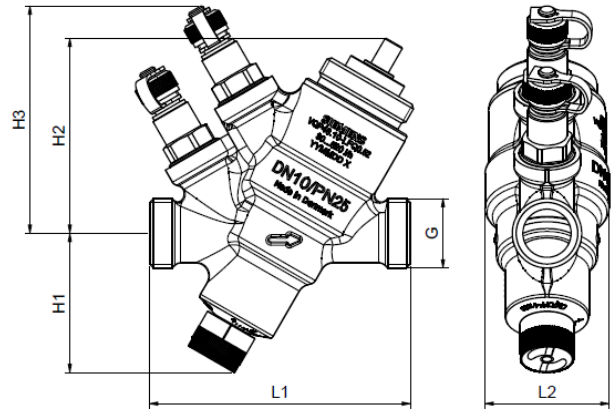

Type	DN	G [inch]	L1 [mm]	L2 [mm]	H1 [mm]	H2 [mm]	H3 [mm]	kg [kg]
VQP46.10L0.5	10	½	70	37	42	59	-	0.339
VQP46.10L0.5Q			79				69	0.442
VQP46.15L0.5	15	¾	75				-	0.362
VQP46.15L0.5Q			84				69	0.465
VQP46.15F1.3			75				-	0.362
VQP46.15F1.3Q			84				69	0.465
VQP46.20F1.5	20	1	80				-	0.396
VQP46.20F1.5Q			90				69	0.518
VQP46.25F1.8	25	1 ¼	87				-	0.478
VQP46.25F1.8Q			98				69	0.594

VQI46..

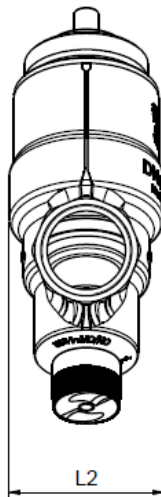
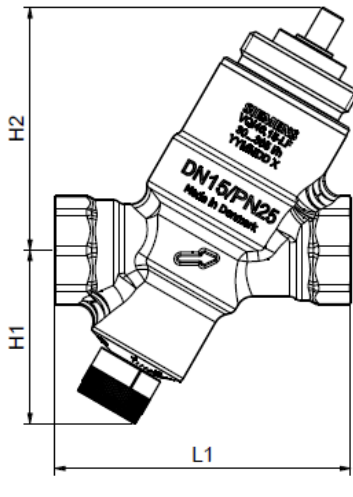

VQI46..Q

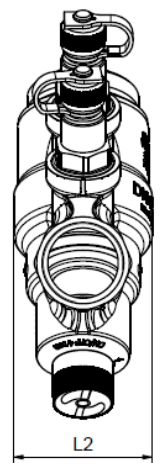
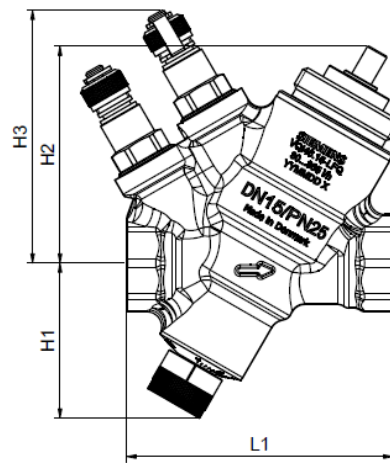

Type	DN	G [inch]	L1 [mm]	L2 [mm]	H1 [mm]	H2 [mm]	H3 [mm]	kg [kg]
VQI46.15L0.5	15	½	72	37	42	59	-	0.360
VQI46.15L0.5Q							69	0.458
VQI46.15F1.3							-	0.360
VQI46.15F1.3Q							69	0.458
VQI46.20F1.5	20	¾	78				-	0.387
VQI46.20F1.5Q							69	0.488
VQI46.25F1.8	25	1	86				-	0.465
VQI46.25F1.8Q							69	0.566

Sets of threaded fittings with flat seal

ALG..2...: set of 2 threaded fittings ¹⁾

ALG132 ALG142	Pipe side with external R threads	
------------------	-----------------------------------	--

Type	for valve type	DN	G [inch]	R [inch]	Rp [inch]	L [mm]	T [mm]
Brass ²⁾							
ALG132	VQP46..10..	10	G ½	R 3/8	-	~ 24	~ 9
ALG142	VQP46..15..	15	G ¾	R ½	-	~ 29.5	~ 12

¹⁾ On valve side: cylindrical thread to ISO 228-1
On pipe side: cylindrical thread to ISO 7-1

²⁾ Maximum medium temperature 100 °C

Revision numbers

Type	Valid from rev. no.	Type	Valid from rev. no.
VQP46.10L0.5	..A	VQI46.15L0.5	..A
VQP46.10L0.5Q	..A	VQI46.15L0.5Q	..A
VQP46.15L0.5	..A	VQI46.15F1.3	..A
VQP46.15L0.5Q	..A	VQI46.15F1.3Q	..A
VQP46.15F1.3	..A	VQI46.20F1.5	..A
VQP46.15F1.3Q	..A	VQI46.20F1.5Q	..A
VQP46.20F1.5	..A	VQI46.25F1.8	..A
VQP46.20F1.5Q	..A	VQI46.25F1.8Q	..A
VQP46.25F1.8	..A		
VQP46.25F1.8Q	..A		