



Synco™ 100

## Immersion Temperature Controller

## RLE132

with 3-position output

---

**Immersion temperature controller for basic heating plants. Compact design with 3-position control. Used as a controller, minimum or maximum limiter.**

### Use

---

**Plant types:**

- Heating zones in heating plants
- Heating section of ventilation or air conditioning plants
- Flow temperature in heating plants
- DHW temperature
- Heat exchanger control
- Calorifier control

**Building types:**

- Residential buildings of all types
- Non-residential buildings of all types

**Used as a limiter:**

- Heating plants controlled by a heating controller with 3-position control, e.g. RVL4..., RVP3..., RVP2...

**Devices that can be controlled:**

- Actuators with 3-position control

## Functions

---

### Main functions

- Control of the water temperature through 3-position control of a seat or slipper valve
- Minimum or maximum limitation of the flow or return temperature, or minimum limitation of the boiler return temperature

### Other functions

- Outside temperature compensation
- Remote setpoint adjustment
- Setpoint changeover via external contact, can be selected to provide temperature setback or legionella function
- Frost protection
- Load-dependent switching contact (e.g. for pump release)
- Test mode as a commissioning aid

## Ordering

---

When ordering, please give type reference **RLE132**.

## Equipment combinations

---

Actuators must meet the following specification:

- 3-position control
- Control contacts suited for AC 24...230 V, 2 A
- Running times:
  - $\geq 30$  s (30 s or 35 s)
  - $\geq 120$  s (120 s, 125 s, 135 s, 150 s or 160 s)

For auxiliary functions, the following products can be used:

<i>Type of unit</i>	<i>Type ref.</i>	<i>Data Sheet</i>
Outside sensor (for outside temperature compensation)	<b>QAC22</b>	N1811
Remote setpoint adjuster	<b>BSG21.1</b>	N1991
Scale 0...130 °C for remote setpoint adjuster	<b>BSG-Z</b>	N1991

As a limiter, the RLE132 can be used in connection with the following types of heating controllers:

<i>Type reference</i>	<i>Data Sheet</i>
RVL470	N2522
RVL471	N2524
RVL472	N2526
RVP201, RVP211	N2464
RVP300	N2474
RVP310	N2475
RVP320	N2476
RVP330	N2477
RVP331	N2478

## Technical design

---

### Mode of operation as a controller

When the water temperature deviates from the setpoint, the controller adjusts the actuating device until the setpoint is reached again. The neutral zone is  $\pm 2$  K. The controller calculates and stores the running time of the connected actuator. Fully open (100 %) corresponds to a heat demand of 100 % (also refer to section "Switching contact").

The controller provides 2 modes of operation (for details refer to section "Operating modes"):

- Control with ECO

- Control with boost

The following settings are required:

- Setpoint
- Control mode: A choice of 4 PI modes are available to suit the type of controlled system (refer to chapter “Mechanical design”)
- P-band

### Mode of operation as a limiter

The control signals of the heating zone controller (RVL4..., RVP3..., RVP2...) are passed to the RLE132 which acts as a limiter.

#### Minimum limitation

1. If the temperature (e.g. the boiler return temperature) falls to a level 4 K above the minimum limit value, the RLE132 interrupts the OPEN signals of the heating zone controller. At the same time, it delivers CLOSE commands in the form of pulses to the mixing valve’s actuator until the temperature rises again.
2. If the temperature falls to the minimum limit value, the RLE132 delivers a constant CLOSE command to the mixing valve’s actuator until the temperature rises again.
3. If the temperature rises, the RLE132 releases the positioning commands of the heating zone controller.

#### Maximum limitation

1. If the temperature (e.g. the flow temperature) rises to a level 4 K below the maximum limit value, the RLE132 interrupts the OPEN signals of the heating zone controller. At the same time, it delivers CLOSE commands to the mixing valve’s actuator in the form of pulses until the temperature falls again.
2. If the temperature reaches the maximum limit value, the RLE132 delivers a constant CLOSE command to the mixing valve’s actuator until the temperature falls again.
3. If the temperature falls, the RLE132 releases the positioning commands of the heating zone controller.

### Outside temperature compensation

When using an outside sensor, the RLE132 provides outside temperature compensation. If the outside temperature falls from +15 to –5 °C, the setpoint will be continuously raised by 0 K to 26 K. Below an outside temperature of –5 °C, the temperature increase will be kept constant.

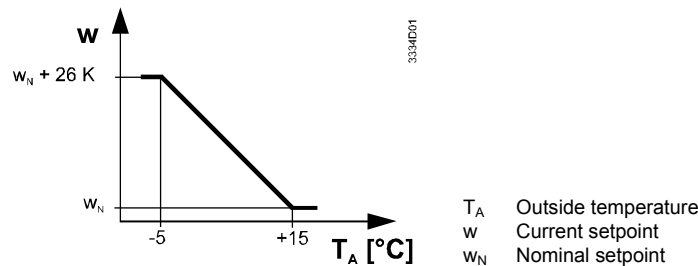

### Remote adjustment of setpoint

Where the controller is mounted in an inaccessible location, a remote setpoint adjuster BSG21.1 can be connected to the RLE132 (terminals R1–M), thus enabling the setpoint to be adjusted from a remote location. In this case, the controller’s setpoint setting slider must be set to EXT.

### Operating modes

#### Control with ECO (setpoint decrease)

In operating mode **Control with ECO**, the nominal setpoint is **reduced** by closing an external potential-free contact across terminals D1–M.

This ensures energy savings, e.g. through night setback of space heating controlled by a time switch.

#### Control with boost (setpoint increase)

In operating mode **Control with boost**, the nominal setpoint is **raised** by closing an external potential-free contact across terminals D1–M.

**Setting** This makes possible legionella protection in DHW heating systems. With the help of a 7-day time switch, the DHW is periodically heated up to the required temperature. A slider is provided to set the temperature by which the nominal setpoint shall be lowered (ECO) or raised (boost). The setting cannot be accessed by the user.

**Switching contact** The switching output (terminals Q13–Q14) enables a plant element to be switched depending on demand, or a limitation alarm to be generated. The mode of operation depends on the operating mode selected on the RLE132:

- When used as a **controller**:  
The switching contact makes when there is a heat demand of 5 %. The contact breaks, when there is no demand (0 %) for a period of 12 minutes.
- When used as a **limiter**:  
The contact makes when the limitation value is reached, and breaks when normal operation is resumed.

**Test mode** In test mode, the control is switched off. The setpoint setting knob acts as a positioning unit:

- If a setting >104 °C is used, the actuating device will open (OPEN command on Y1)
- If a setting <26 °C is used, the actuating device will close (CLOSE command on Y2)

The test mode is indicated by an LED.

**Mechanical design**

The controller is designed for mounting into piping. It consists of a housing and cover and an immersion rod. The rod contains the sensing element (LG-Ni 1000). The housing is made of plastic and accommodates the controller electronics and all operating elements, which are accessible only after removing the cover. The front carries the setpoint setting slider and an LED for indicating operation:

- LED lit: normal operation
- LED flashes: test mode

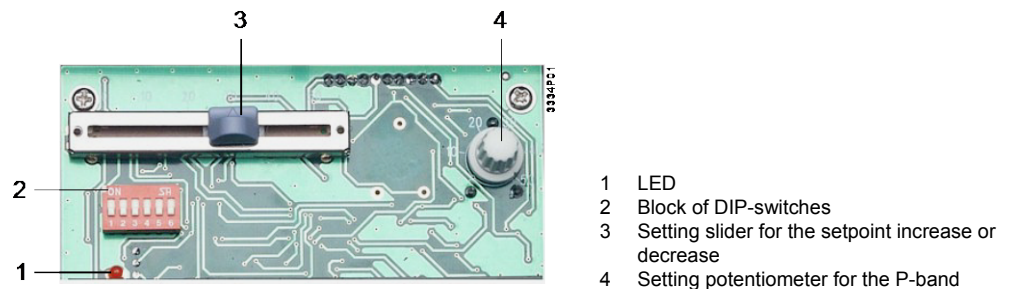

All functions are selected via the DIP switch block which comprises 6 switches:

Function	1	2	3	4	5	6	Action
Operating	■	■					Heating with boost; setpoint increase
	■	┌					Maximum limitation
	┌	■					Minimum limitation
Integral action time	┌	┌					Heating with ECO; setpoint decrease
			■	■			VERY SLOW, T <sub>N</sub> = 300 s
			■	┌			SLOW, T <sub>N</sub> = 180 s
			┌	■			FAST, T <sub>N</sub> = 60 s
Test mode			┌	┌			MEDIUM, T <sub>N</sub> = 120 s
					■		Test mode
Running time of actuator					┌		Normal operation
						■	≥30 s
						┌	≥120 s

For mounting, a protection pocket is provided; the controller is inserted and snaps on.

## Engineering notes

---

The controller is supplied complete with Mounting and Installation Instructions.

## Mounting notes

---

Ensure that the local safety regulations are complied with.

Suitable mounting locations are the following, depending on the application:

- Flow temperature control:
  - In the heating flow; immediately after the pump if the pump is mounted in the flow
  - In the heating flow; approximately 1.5 to 2 m after the mixing point if the pump is mounted in the return
- Minimum limitation of the boiler return temperature and maximum limitation of the flow temperature:  
1.5 to 2 m after the mixing point
- DHW temperature control:  
1.5 to 2 m after the mixing point
- Heat exchanger control:  
As close as possible to the heat exchanger while observing the maximum permissible ambient temperature

To mount the protection pocket, a threaded sleeve must be fitted into the pipe. The immersion rod should face the direction of flow. The maximum permissible ambient temperature must be observed.



### Warning!

#### **No internal line protection for supply lines to external consumers.**

Risk of fire and injury due to short-circuits!

- Adapt the line diameters as per local regulations to the rated value of the installed overcurrent protection device.
- The AC 230 V mains supply line must have an external circuit breaker with a rated current of no more than 10 A.

## Commissioning notes

---

To check the control wiring, the controller can be switched into test mode so that the response of the actuating device can be checked.

In case of instability of the control loop, the P-band is to be increased, and/or the integral action time selection. If the response of the system is too slow, these values are to be reduced.

## Disposal

---



The devices are considered electronics devices for disposal in terms of European Directive 2012/19/EU and may not be disposed of as domestic waste.

- Dispose of the device via the channels provided for this purpose.
- Comply with all local and currently applicable laws and regulations.

## Technical data

### Power Supply

Operating voltage	AC 230 V +10% / -15%
Frequency	50 / 60 Hz
Power consumption	max. 4 VA



#### No internal fuse.

External preliminary protection with max. C 10 A circuit breaker in the supply line required under all circumstances.

### Functional Data

Setting range nominal setpoint	0...130 °C
Setting range setpoint changeover	0...50 K
P-band	1...50 K
Integral action time with PI control	selectable (60 / 120 / 180 / 300 s)
Control outputs Y1, Y2	
Voltage	AC 24...230 V
Current	max. 2 A
Control outputs Q13-Q14	
Voltage	AC 24...230 V
Current	max. 2 A
Max. cable length copper cable 1.5 mm <sup>2</sup>	
For signal input B9	80 m
For switching input D1	80 m
Contact sensing (input D1-M)	DC 6...15 V, 3...6 mA

### Environmental conditions

Operation	
Climatic conditions	to IEC 60721-3-3, class 3K5
Temperature	0...+50 °C
Humidity	<95 % r.h.
Transport	
Climatic conditions	to IEC 60721-3-2, class 2K3
Temperature	-25...+70 °C
Humidity	<95 % r.h.
Mechanical conditions	class 2M2

### Norms and standards

EU Conformity (CE)	CE1T3330xx *)
Degree of protection	IP65 EN 60529
Safety class	II to EN 60730
Degree of contamination	normal

### Environmental compatibility

The product environmental declaration CE1E3333en \*) contains data on environmentally compatible product design and assessments (RoHS compliance, materials composition, packaging, environmental benefit, disposal).

### General

Connection terminals for solid wires or stranded wires	2 × 1.5 mm <sup>2</sup> or 1 × 2.5 mm <sup>2</sup>
Sensor	
Sensing element	LG-Ni 1000 Ω at 0 °C
Time constant (with protection pocket)	25 s
Protection pocket	
Immersion depth	150 mm
Perm. nominal pressure	PN10
Made of	brass (Ms63)
Weight	0.3 kg

\*) The documents can be downloaded from <http://siemens.com/bt/download>.

## Connection terminals

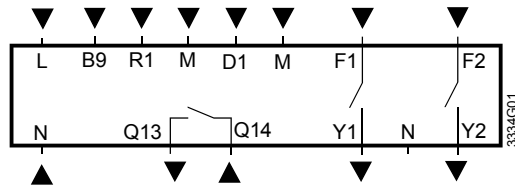

- B9 Outside sensor
- D1 Input for setpoint changeover
- F1 Input for Y1
- F2 Input for Y2
- L, N Operating voltage AC 230 V
- M Ground
- R1 Input for remote setpoint adjuster
- Q13 Switching contact
- Q14 Switching contact
- Y1 Control output for mixing valve OPEN
- Y2 Control output for mixing valve CLOSED

## Connection diagram

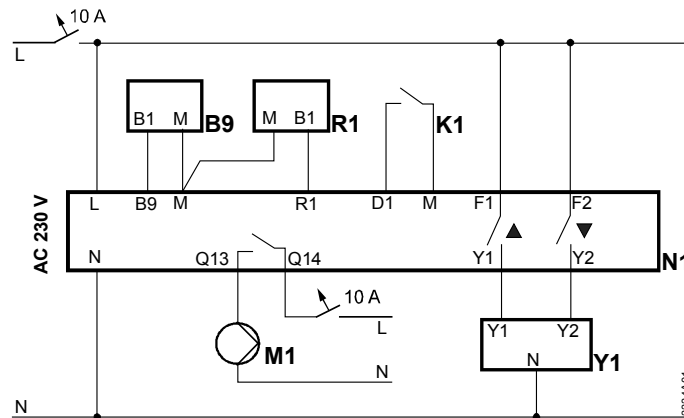

Used as a controller, flow temperature with outside temperature compensation, remote setting unit, setpoint changeover and demand control of a pump

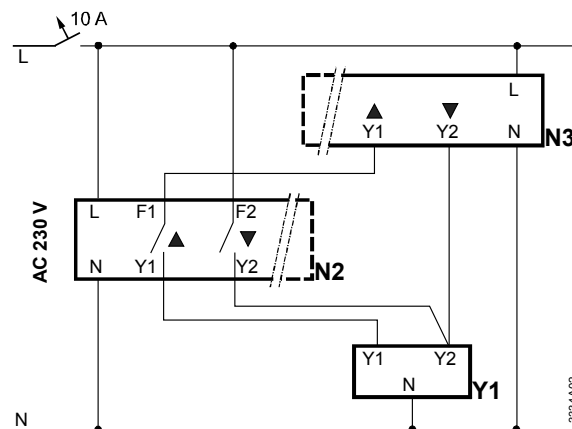

Used as a limiter in connection with a heating zone controller (RVL4..., RVP3..., RVP2...), e.g. minimum limitation of the boiler return temperature or maximum limitation of the boiler flow temperature

- B9 Outside sensor QAC22
- K1 External contact (e.g. time switch)
- M1 Pump
- N1 Immersion temperature controller RLE132
- N2 Immersion temperature controller RLE132 as a limiter
- N3 Heating controller RVL4..., RVP3..., RVP2...
- R1 Remote setpoint adjuster BSG21.1
- Y1 Actuator of heating circuit valve

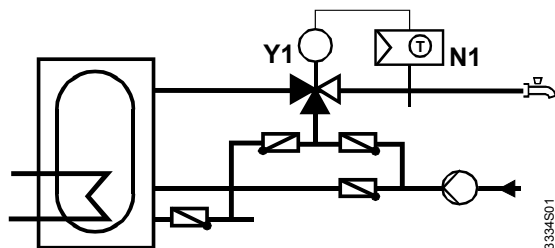

DHW temperature control

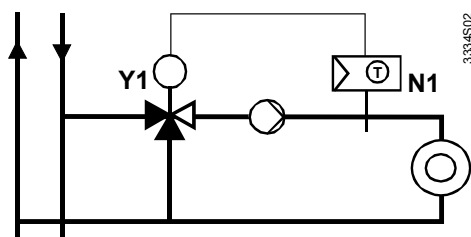

Flow temperature control in a heating zone with a common flow

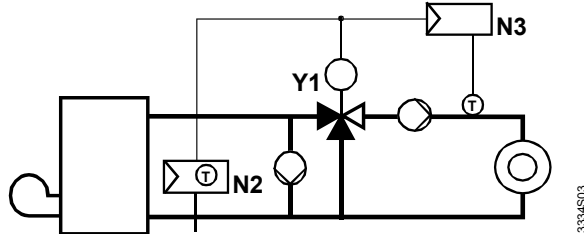

Control of a heating zone with zone controller RV..., minimum limitation of the boiler return temperature with RLE132

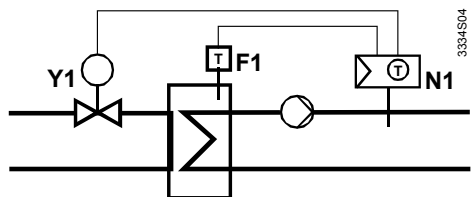

Heat exchanger control with 2-port valve in the primary flow

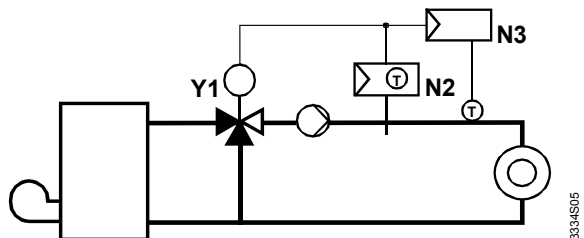

Control of a heating zone with zone controller RV..., maximum limitation of the flow temperature with RLE132

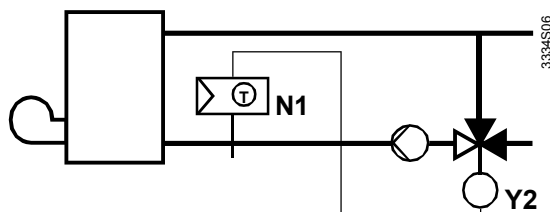

Control of the boiler return temperature

- F1 Safety limit thermostat
- N1 Immersion temperature controller RLE132 as a controller
- N2 Immersion temperature controller RLE132 as a limiter
- N3 Heating zone controller RVL4..., RVP3..., RVP2...
- Y1 Heating circuit mixing valve or primary circuit valve or DHW mixing valve
- Y2 Mixing valve, boiler return circuit



## Dimensions

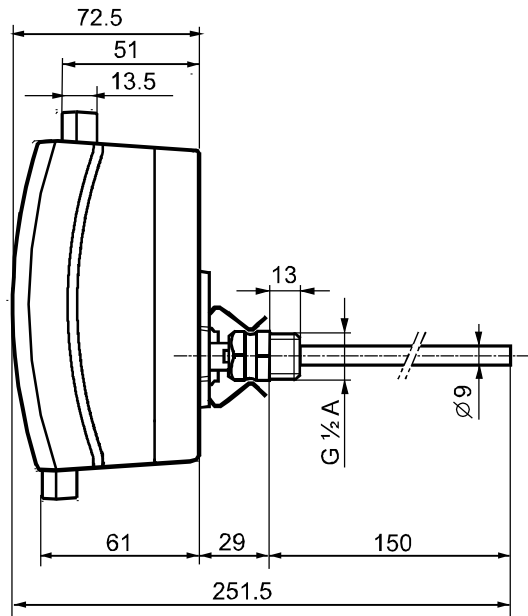

Controller with protection pocket

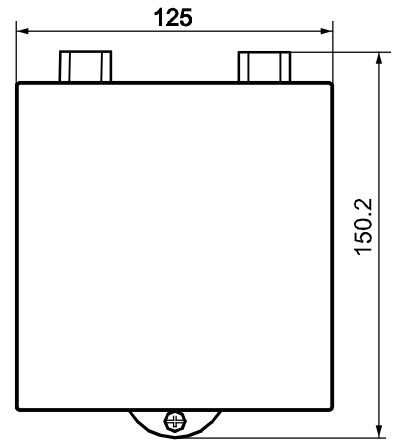

3334M01

Dimensions in mm

