



OpenAir™

Fast running actuators for air dampers

GAP19...

Fast runner rotary version, AC/DC 24 V

Electronic actuator for 2-position, 3-position, or modulating control, nominal torque 6 Nm, at 2 s running time, self-centering shaft adapter, range mechanically adjustable between 0...90°, prewired with 0.9 m long standard connection cables. GAP196.1E with adjustable auxiliary switches for auxiliary functions.

Use

- For damper areas up to ca. 1 m², friction dependent.
- For laboratory fume hoods, etc.
- Suitable for use with continuous, 2-position, or 3-position controllers.

Type summary

Types	Power	Auxiliary switch	Torque	Damper size	Runtime
GAP191.1E	AC/DC 24 V	No	6 Nm	Ca. 1 m ²	2 s
GAP196.1E		Yes			

Factory setting

The actuator is preset at the factory to:

- 0...10 V
- Clockwise rotary movement.

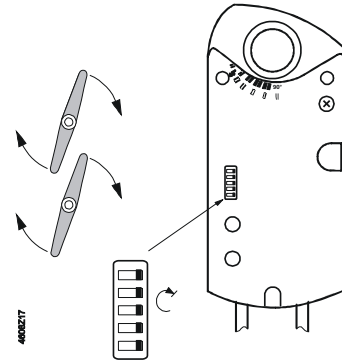

Functions

DIL switch setting		A DIL switch is used to set the actuator's functionality.						
Siemens default setting	Continuous control				2-position control	3-position control		
	DC 0..10 V	DC 2..10 V	0..20 mA	4..20 mA	2-Pt	3-Pt		

Position indication: Mechanical	Rotary angle position.
Position indication: Electric.	Output voltage $U = DC\ 0...10\ V$ is generated proportional to rotary angle. U depends on the DIL switch's rotary direction position.
Rotary angle limitation	The rotary angle of the shaft adapter can be limited mechanically to 5° increments.
GAP196.1E auxiliary switch	The switching points for auxiliary switches A and B can be set mutually independent in 5° increments from 0 to 90°.

Ordering

Delivery	Individual parts such as shaft adapter with position indication and other mounting materials for the actuator are delivered unassembled .
Accessories, spare parts	Various accessories are available to extend the actuators' functionality; e.g. rotary/linear mounting kit, external auxiliary switch (1 or 2 switches) and weather shield; see data sheet N4697 .

Technical data

⚠ 24 VAC/VDC supply (SELV/PELV)	Operating voltage / Frequency	AC/DC 24 V ± 20 % / 50/60 Hz	
	Power consumption:	Actuator running 30 VA / 22 W Hold 5 W	
Functional data	Nominal torque	6 Nm	
	Maximum torque (when blocked)	18 Nm	
	Nominal rotary angle / max. rotary angle	90° / max. 95° ± 2°	
	Runtime for 90° rotary angle	2 s	
Positioning signal Y/Y1	Input voltage Y/Y1+ (wires 8-2)	DC 0 (2)...10 V / 0 (4)...20 mA or AC/DC 0 V , AC/DC 24 V "open"	
	Positioning resolution for DC 0 (2)...10 V / 0 (4)...20 mA	250 steps for 90 °	
	<u>Max. permissible input voltage</u>	AC/DC 24 V ± 20 %	
Positioning signal Y2	Input voltage Y2+ (wires 7-2)	AC/DC 0 V , AC/DC 24 V "close"	
	<u>Max. permissible input voltage</u>	AC/DC 24 V ± 20 %	
Position indicator	Output voltage U (wires 9-2)	DC 0 (2)...10 V	
	max. output current	DC ± 1 mA	
⚠ Auxiliary switch for GAP196	Contact loading	6 A resistive, 2 A inductive	
	Voltage (no mixed operation AC 24 V / AC 230 V)	AC 24...230 V	
	Switching range for auxiliary switches	5°...90°	
	Setting increments	5°	
Connection cable	Cross-sectional area	0.75 mm ²	
	Standard length	0.9 m	
Housing type Protection class	Protection class as per EN 60 529 (observe mounting notes)	IP 54	
	Insulation class 230 VAC, auxiliary switch	EN 60 730 II	
Environmental conditions	Operation / Transport	IEC 721-3-3 / IEC 721-3-2	
	Temperature	-32...+50 °C / -32...+70 °C	
	Humidity (non-condensing)	< 95% r. h. / < 95% r. h.	
Standards, guidelines	Product safety: Automatic electronic controls for household and similar use	EN 60 730-2-14 (Type 1)	
	Electromagnetic compatibility (EMC)		
	Immunity	IEC/EN 61 000-6-2	
	Emissions	IEC/EN 61 000-6-3	
	CE Conformity		
	Electromagnetic compatibility	2004/108/EC	
	Low-voltage directive	2006/95/EC	
	Conformity		
Australian EMC Framework Radio Interference Emission Standard	Radio Communication Act 1992 AS/NZS 3548		
Dimensions	Actuator W x H x D (see Dimensions)	81 x 192 x 63 mm	
	Damper shaft:	round	6.4... 20.5 mm
		square	6.4... 13 mm
	Min. shaft length	20 mm	
Weight	Excl. packaging	1.260 kg	

Disposal

See "Technical basics" and the environmental declaration for information on environmental compatibility and device disposal.

2-position control

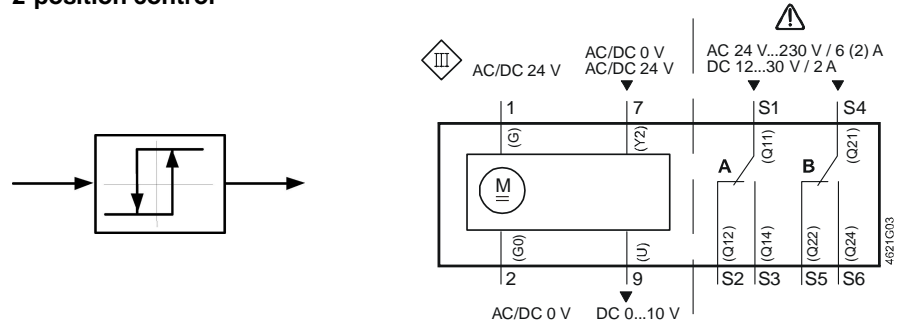

3-position control

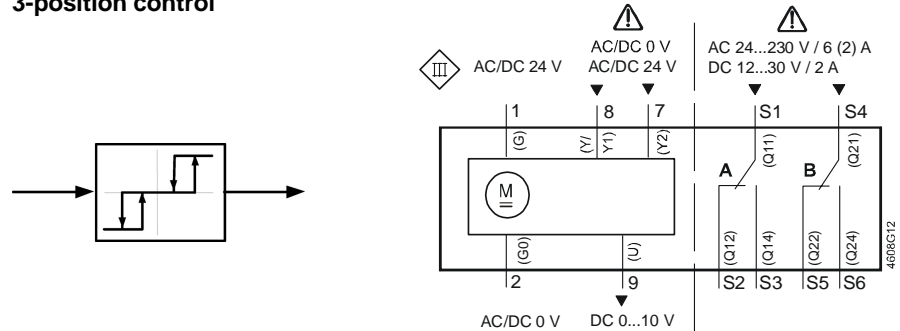

Modulating control

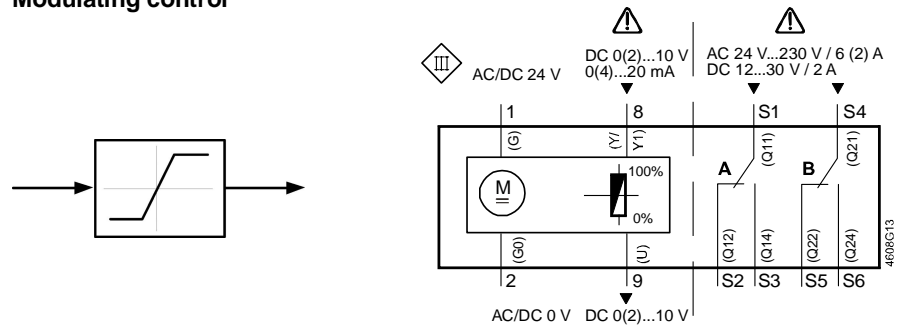

Cable designations

Pin	Cable				Meaning
	Code	No.	Color	Abbr.	
Actuators 24 VAC/VDC	G	1	red	RD	AC/DC 24 V system potential
	G0	2	black	BK	System ground
	Y2	7	orange	OG	Pos. signal AC/DC 0 V, AC/DC 24 V "close"
	Y/Y1	8	gray	GY	Pos. Signal DC 0 (2)...10 V 0 (4)...20 mA or Pos. signal AC/DC 0 V, AC/DC 24 V "open"
	U	9	rose	PK	Position indication DC 0 (2)...10 V
Auxiliary switch	Q11	S1	gray/red	GYRD	Switch A input
	Q12	S2	gray/blue	GYBU	Switch A Normally closed contact
	Q14	S3	gray/rose	GYPK	Switch A Normally open contact
	Q21	S4	black/red	BKRD	Switch B input
	Q22	S5	black/blue	BKBU	Switch B Normally closed contact
	Q24	S6	black/rose	BKPK	Switch B Normally open contact

Dimensions

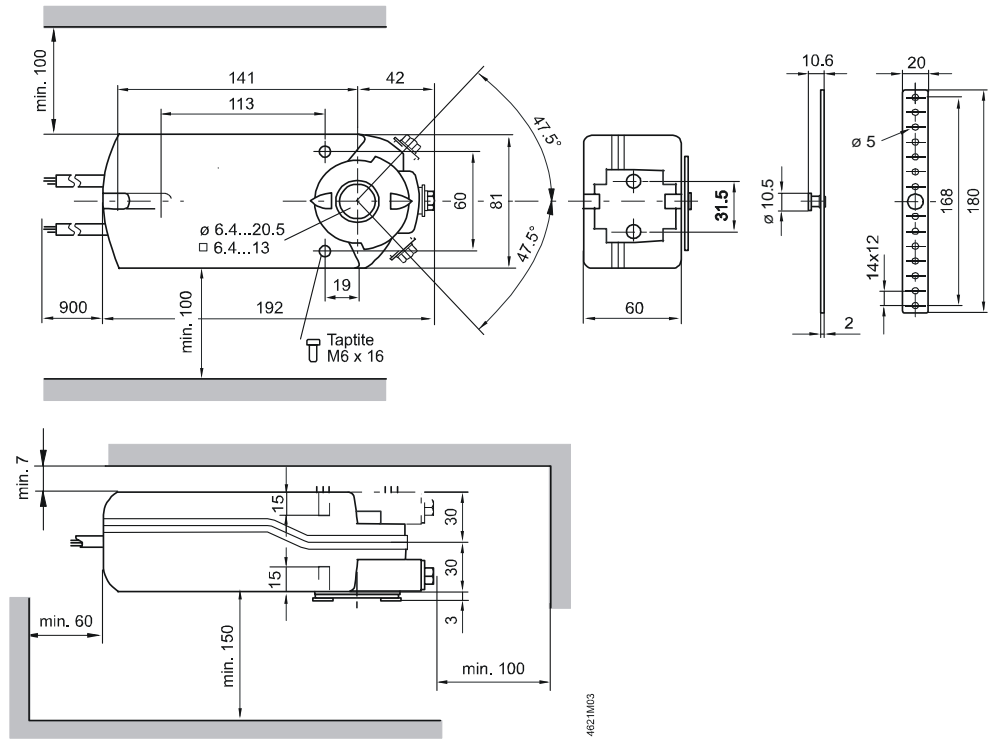

Dimensions in mm